

# RS-232 To RS-422 / RS-485 BIDIRECTIONAL CONVERTER



**USER MANUAL**

---

**IC-485AI**

2002-09-27

**Note:** This equipment has been tested and found to comply with the limits for a Class A digital device pursuant to Part 15 of the FCC Rules. These limits are designed to provide reasonable protection against harmful interference when the equipment is operated in a commercial environment. This equipment generates, uses, and can radiate radio frequency energy and, if not installed and used in accordance with the instruction manual, may cause harmful interference to radio communications. Operation of this equipment in a residential area is likely to cause harmful interference, in which case the user will be required to correct the interference at his own expense.

2002-09-27

# PACKING LIST

This package consists of:

- 1 IC-485AI Bidirectional Isolated Converter
- 1 Power Adapter
- 1 User Manual

Check to make sure that the unit was not damaged in shipping. If you encounter a problem, contact your dealer.

Read this manual thoroughly and follow the installation and operation procedures carefully to prevent any damage to the unit, and/or any of the devices connected to it.

© Copyright 2001 ATEN<sup>®</sup> International Co., Ltd.  
Manual Part No. PAPE-0194-100  
Printed in Taiwan 02/2002



All brand names and trademarks are the registered property of their respective owners.

# CONTENTS

Overview .....	1
Features .....	2
Components .....	3
Top View: .....	3
Bottom View: .....	4
DIP Switch Configuration .....	5
Operating Modes .....	7
Point-to-Point .....	7
Multidrop .....	9
Simplex .....	11
Installation .....	12
RS-422 / RS-485 Installation Diagrams .....	13
Appendix .....	14
Terminal Block Pin Assignments .....	14
Circuit Test .....	14
RS-485 Operation Mode Flow Charts .....	15
DCE / DTE Connection Description .....	17
Specifications .....	18
Troubleshooting .....	19
Limited Warranty .....	19

## OVERVIEW

Although RS-232 serial ports are found on almost every computer, because of their slow transmission speeds, limited range, and limited networking capabilities, they are not an effective solution for industrial strength long distance communications systems.

Systems based on the RS-422 and RS-485 standards, on the other hand, are not subject to the RS-232 limitations because they utilize different voltage lines for the data and control signals.

The IC-485AI Isolated Converter is a bidirectional converter that transparently converts RS-232 signals to RS-422 / RS-485 signals (and vice versa), thus permitting the creation of reliable long distance data communications systems using standard computer hardware.

The IC-485AI provides Point-to-Point; Multidrop; and Simplex operations over distances of up to 1200 m (4000 ft.). Designed with built in optocouplers for exceptional signal isolation, plus transformers for excellent power isolation, this extremely reliable isolated converter enhances the quality of data communications at the same time that it protects your equipment from electrical surges of up to 2000 volts.

## FEATURES

- ♦ Automatic internal RS-485 bus supervision
- ♦ No external flow control signals for RS-485 required
- ♦ Transient suppression on RS-485 data lines
- ♦ LEDs for easy status monitoring
- ♦ Minimum 2000V isolation protection
- ♦ Up to 115.2 Kbps data throughput
- ♦ DCE / DTE selectable
- ♦ Point-to-Point; Multidrop; and Simplex operating modes
- ♦ Four wire full duplex; two wire half duplex
- ♦ Cable distance of up to 1200 m (4000 ft.)
- ♦ Compact size

# COMPONENTS

## TOP VIEW:

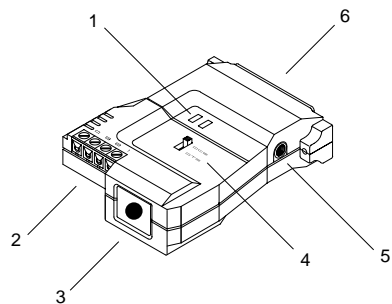

### 1. Status LEDs

- ♦ RTS: Lights to indicate that RTS has been pulled high.
- ♦ TxD: Flashes when data transmission occurs.

### 2. RS-422 / RS-485 Terminal Block

### 3. Grounding Tab

### 4. DCE /DTE Selection Switch

If the IC-485AI is going to be plugged into a DTE device, the switch must be set to DCE, and vice versa.

### 5. Power Jack

The cable from the Power Adapter plugs in here.

### 6. RS-232 DB-25 Female Connector

**BOTTOM VIEW:**

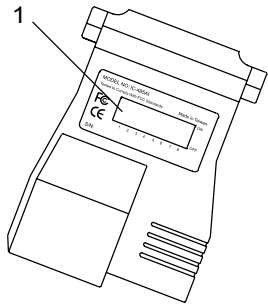

**1. DIP Switch**

This eight segment DIP Switch, located on the unit's bottom panel, is used to configure the switch's operating parameters.



## DIP SWITCH CONFIGURATION

The IC-485AI's settings for Baud Rate, Data Format, and RS-422 / RS-485 Mode are configured by setting the eight segment DIP Switch located on its bottom panel.

**Note:** When you change any of the DIP Switch settings, you must reset the device by powering it off, then powering it on again.

### ◆ SW 1-3: Baud Rate

Baud Rate	SW1	SW2	SW3
1200	ON	ON	ON
2400	OFF	ON	ON
4800	ON	OFF	ON
9600	OFF	OFF	ON
19200	ON	ON	OFF
38400	OFF	ON	OFF
57600	ON	OFF	OFF
115200	OFF	OFF	OFF

**Note:** 1. The Baud Rate must be the same for all units on the installation.  
2. The default is 9600 bps.

### ◆ SW 4: Reserved

◆ **SW 5-6: Data Format**

These two switch segments configure the bit settings for Start, Data, Parity, and Stop.

Data Format (bits)	SW5	SW6
9	ON	ON
10	OFF	ON
11	ON	OFF
12	OFF	OFF

**Note:** The default is 10 bits (1 Start; 8 Data; 0 Parity; 1 Stop). Unless you have a special reason to change this, we recommend that you leave it as is. If you do change it, however, all the units on the installation must be changed to match.

◆ **SW 7-8: RS-422 / RS-485 Operating Mode**

SW7 determines whether the unit operates as an RS-422 or RS-485 converter.

- ◆ As an RS-422 converter, SW8 determines whether the unit is configured for Master or Slave operation.
- ◆ As an RS-485 converter, SW8 determines whether the unit operates in RTS Control Mode or Auto Send Data Mode.

Operating modes are discussed in detail in the next section and on p. 15.

**Note:** RS-422 is used for 4 wire hookups; RS-485 is used for 2 wire hookups.

Operating Mode	SW7	SW8
RS-422 Master	ON	ON
RS-422 Slave	ON	OFF
RS-485 Auto Send Data Mode	OFF	ON
RS-485 RTS Control Mode	OFF	OFF

# OPERATING MODES

The IC-485AI supports three operating modes: Point-to-Point; Multidrop; and Simplex. Point-to-Point and Multidrop can be configured for Full or Half Duplex. Each of the operating modes is explained below.

## POINT-TO-POINT

A Point-to-Point configuration is one in which two devices, located at two different places are linked for communication by a pair of IC-485AI units. There are two configurations: Point-to-Point Full Duplex, and Point-to-Point Half Duplex.

### 1. Point-to-Point 4 Wire Full Duplex

- Point-to-Point Full Duplex uses reverse four wire cabling, as shown in the diagram below.

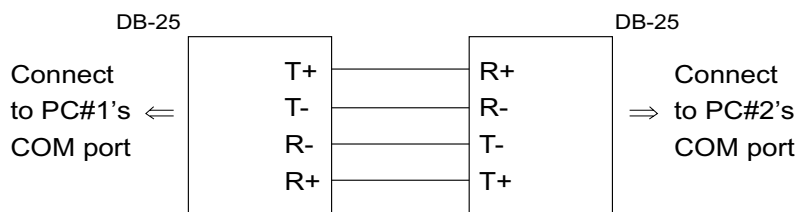

- For both IC-485AI units, set the unit to DCE or DTE depending on what type of device the IC-485AI will plug into (if it will plug into a DCE device, configure it for DTE, and vice versa).
- Set SW7 and SW8 **ON** for both units. They are now configured for RS-422 Master operation.

## 2. Point-to-Point 2 Wire Half Duplex

- Point-to-Point Half Duplex uses straight through two wire cabling, as shown in the diagram below.

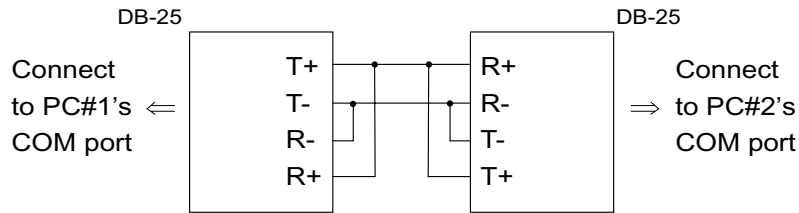

- For both IC-485AI units, set the unit to DCE or DTE depending on what type of device the IC-485AI will plug into (if it will plug into a DCE device, configure it for DTE, and vice versa).
- Set SW7 **OFF** and SW8 **ON** for both units. They are now configured for RS-485 Auto Send Data Mode (see p. 15 for RS-485 operation details).

## MULTIDROP

A Multidrop configuration is one in which more than two devices are linked for communication using several IC-485AI units. One of the devices that one of the IC-485AIs connects to is designated as the *Master* device. All the remaining devices that the rest of the IC-485AIs connect to are designated as *Slave* devices. Up to 31 Slave devices can be connected. There are two configurations: Multidrop Full Duplex, and Multidrop Half Duplex.

### 1. Multidrop Full Duplex

- Multidrop Full Duplex uses reverse four wire cabling, to link all the connected IC-485AI units:

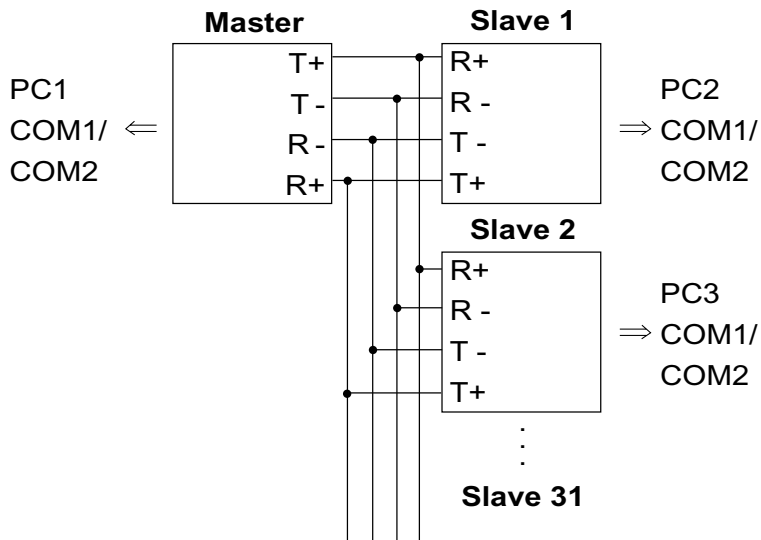

- For all IC-485AI units, set the unit to DCE or DTE depending on what type of device the IC-485AI will plug into (if it will plug into a DCE device, configure it for DTE, and vice versa).
- For the Master unit, set SW7 **ON**; set SW8 **ON** (RS-422 Master mode).
- For all of the Slave units, set SW7 **ON**; set SW8 **OFF** (RS-422 Slave mode).

**Note:** 1. No more than 31 Slave units can be connected.

2. When any of the Slave units transmits data, none of the other Slaves may transmit. RTS for all other Slave units must be pulled low.

## 2. Multidrop Half Duplex

Multidrop Half Duplex uses reverse two wire cabling, to link all the connected IC-485AI units:

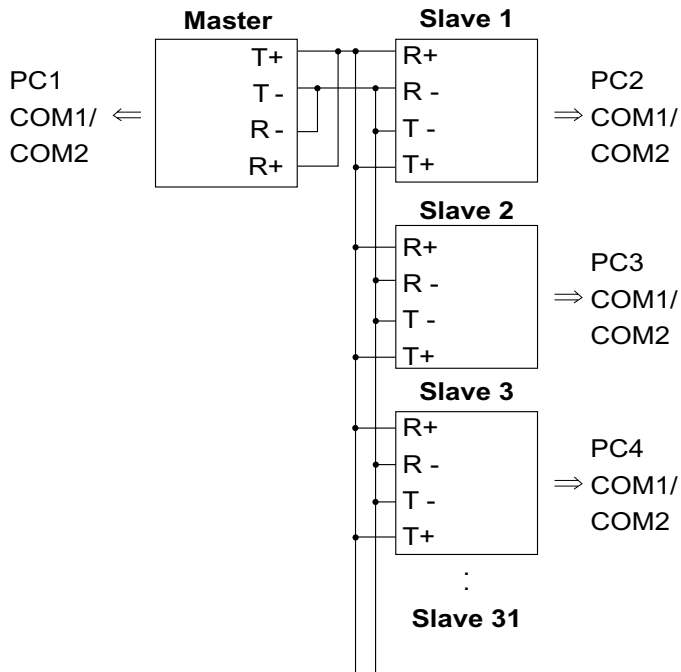

- For all IC-485AI units, set the unit to DCE or DTE depending on what type of device the IC-485AI will plug into (if it will plug into a DCE device, configure it for DTE, and vice versa).
- For all of the units set SW7 and SW8 according to the table on p. 6 to configure each unit's RS-485 operating mode (see p. 15 for RS-485 operation details).

**Note:** No more than 31 Slave units can be connected.

## SIMPLEX

A Simplex configuration is one in which more than two devices are linked for communication using several IC-485AI units in a manner similar to Multidrop. The difference is that in a Simplex configuration, the Master device can only talk, and the Slave devices can only listen.

- Simplex uses reverse two wire cabling to link all the connected IC-485AI units, as shown in the figure below:

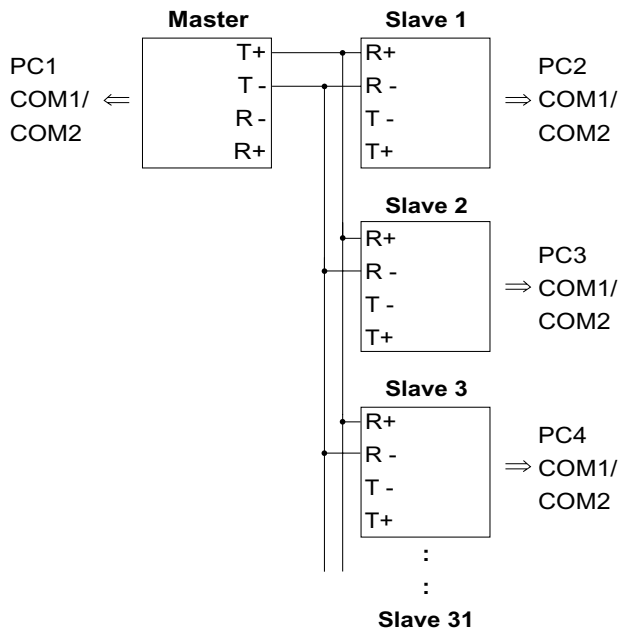

- For all IC-485AI units, set the unit to DCE or DTE depending on what type of device the IC-485AI will plug into (if it will plug into a DCE device, configure it for DTE, and vice versa).
- For all of the units (Master and Slave), set SW7 **ON**; set SW8 **ON**.

**Note:** No more than 31 Slave units can be connected.

# INSTALLATION

1. Make sure that all the devices you will be connecting up are powered off.
2. Set each IC-485AI's configuration switches according to the information provided in the *Switch Configuration* and *Operating Modes* sections.
3. Plug the IC-485AI's DB-25 female connector into the computer's RS-232C port.
4. Connect the IC-485AI units to each other.
  1. Use two or four wire twisted pair cable in a reverse or straight through configuration according to the information provided in the *Switch Configuration* and *Operating Modes* sections.
  2. See p. 14 for the Terminal Block pin assignments.
5. Power on the computers. The units are now ready for operation.

**Note:** When connecting units over long distances, it may be necessary to install 120  $\Omega$  resistors. See the diagrams on the next page for details.



**RS-422 / RS-485 INSTALLATION DIAGRAMS**

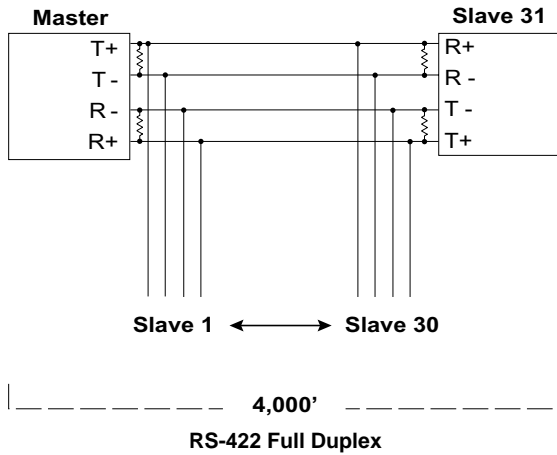

**Note:** When the distance between both ends of the installation is large and/or the transmitted signals are unstable, insert 120 Ω terminal resistors between pins 1 and 2 and between pins 3 and 4 on the terminal blocks of the two units at each end of the installation.

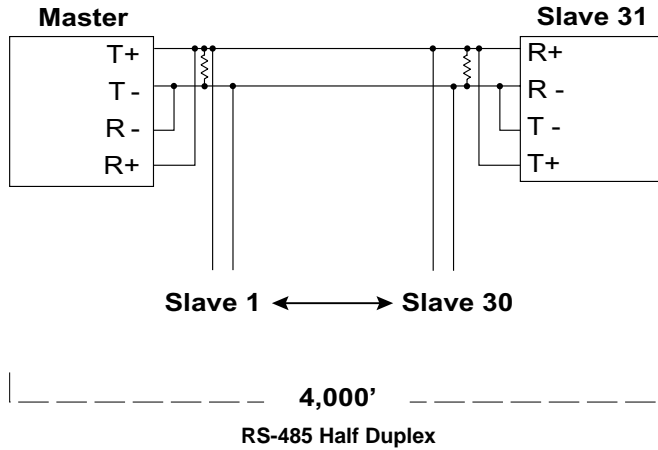

**Note:** When the distance between both ends of the installation is large and/or the transmitted signals aren't stable, insert a 120 Ω terminal resistor between pins 1 and 2 on the terminal blocks of the two units at each end of the installation.

2002-09-27

# APPENDIX

## TERMINAL BLOCK PIN ASSIGNMENTS

Pin	DCE / DTE
1	Transmit +V
2	Transmit -V
3	Receive -V
4	Receive +V

## CIRCUIT TEST

To test the IC-485AI's internal circuits, connect a dumb terminal to the unit and do the following:

1. Set the DCE / DTE switch to the opposite of the terminal.
2. Set all DIP Switch segments to **ON**.
3. Connect one wire from Tx+ (1) to Rx+ (4); connect a second wire from Tx- (2) to Rx- (3).
4. Set the terminal to *Full Duplex*.
5. Set the baud rate of the communication application to 1200 bps.
6. Enter data.

If the circuit is operational, data appears on the screen.

## RS-485 OPERATION MODE FLOW CHARTS

### ◆ RTS Control Mode

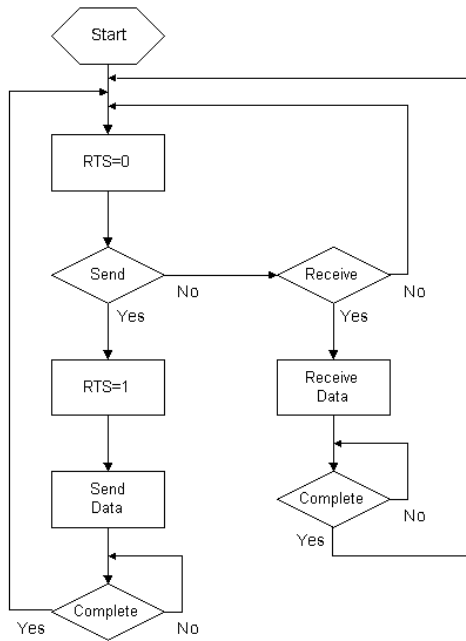

- ◆ The IC-485AI operates in *RS-485 RTS Control Mode* when both SW7 and SW8 are set to **OFF**.
- ◆ In this mode, RTS is pulled high when the computer makes a request to send data.

◆ Auto Send Data Mode

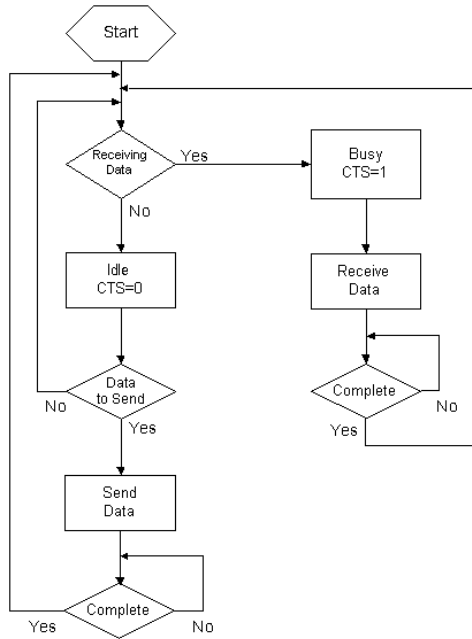

- ◆ The IC-485AI operates in *RS-485 Auto Send Data Mode* when SW7 is set to **OFF**, and SW8 is set to **ON**.
- ◆ In this mode, the status of the bus line is auto-detected in order to prevent more than one signal on the line.
- ◆ If the the bus line is busy, CTS is pulled high, and the IC-485AI will not send data to the bus line.
- ◆ If the bus line is determined to be idle, CTS is pulled low and the IC-485AI sends data to the bus line.

## DCE / DTE CONNECTION DESCRIPTION

Device's Connector Pin #				Cable	IC-485AI	
DCE DB-9	DTE DB-9	DCE DB-25	DTE DB-25	25/25 or 9/25 pin	DCE DB-25	DTE DB-25
		1	1	(PG)	1	1
2	3	3	2	Tx → Rx	2	3
3	2	2	3	Rx ← Tx	3	2
8	7	5	4	RTS → CTS	4	5
7	8	4	5	CTS ← RTS	5	4
6	6	6	6	(DSR)	6	6
5	5	7	7	— SG —	7	7
1	1	8	8	(CD)	8	8
		9	9		9	9
		10	10		10	10
		11	11		11	11
		12	12	(SCD)	12	12
		13	13	(SCS)	13	13
		14	14	(STD)	14	14
		15	15	(TC)	15	15
		16	16	(SRD)	16	16
		17	17	(RC)	17	17
		18	18		18	18
		19	19	(SRS)	19	19
4	4	20	20	(DTR)	20	20
		21	21	(SQD)	21	21
9	9	22	22	(RI)	22	22
		23	23	(DRS)	23	23
		24	24	(XTC)	24	24
		25	25		25	25

## SPECIFICATIONS

Function		Specification
Power Consumption		DC 9V; 900mW (max.)
Data Rate		Up to 115.2 Kbps under 1200 m (4000 ft.)
Connectors		1 x DB-25 female (RS-232); 1 x 4 Post Terminal Block (RS-422 / RS-485); 1 x Grounding Tab
Function Switches	Slide Switch	DCE / DTE Select
	DIP Switch	Segment 1-3: Baud Rate; Segment 4: Reserved; Segment 5&6: Data Format (bits); Segment 7&8: RS-422 / RS-485 Select
Cable Distance		Up to 1200 m (4000 ft.)
Operating Temperature		0 ~ 50° C
Storage Temperature		-20 ~ 60° C
Humidity		0 ~ 80% RH
Housing		Plastic (ABS)
Weight		60 g
Dimensions (L x W x H)		54 x 74.5 x 18.5 mm

## TROUBLESHOOTING

Symptom	Action
Data Transmission Failure	Check that IC-485AI units are securely plugged into the computers' serial ports.
	Check that the cables are properly set up and properly connected.
	Check that SW1 and the DIP Switch are set properly.
	Insert terminal resistors according to the information given on p. 13
Data Loss or Error	Check that the Data Rate and Data Format are the same for all devices.
	Insert terminal resistors according to the information given on p. 13

## LIMITED WARRANTY

IN NO EVENT SHALL THE DIRECT VENDOR'S LIABILITY EXCEED THE PRICE PAID FOR THE PRODUCT FROM THE DIRECT, INDIRECT, SPECIAL, INCIDENTAL OR CONSEQUENTIAL DAMAGES RESULTING FROM THE USE OF THE PRODUCT, DISK OR ITS DOCUMENTATION.

The direct vendor makes no warranty or representation, expressed, implied, or statutory with respect to the contents or use of this documentation, and specially disclaims its quality, performance, merchantability, or fitness for any particular purpose.

The direct vendor also reserves the right to revise or update the device or documentation without obligation to notify any individual or entity of such revisions, or update. For further inquiries please contact your direct vendor.