

# BI-DIRECTIONAL CONVERTER

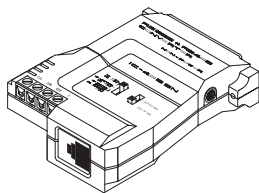

USER'S MANUAL

---

IC-4855N

## Unpacking

**The IC-485SN package contains:**  
**- One IC-485SN Converter**  
**- One User Manual**

Check to see if the product has been damaged in shipping.  
If you encounter a problem, contact your dealer right away.

### **SJ/T 11364-2006**

The following contains information that relates to China

部件名称	有毒有害物质或元素					
	铅	汞	镉	六价铬	多溴联苯	多溴二苯醚
电器部件	●	○	○	○	○	○
机构部件	○	○	○	○	○	○

- : 表示该有毒有害物质在该部件所有均质材料中的含量均在SJ/T 11363-2006规定的限量要求之下。
- : 表示符合欧盟的豁免条款, 但该有毒有害物质至少在该部件的某一均质材料中的含量超出SJ/T 11363-2006的限量要求。
- ×: 表示该有毒有害物质至少在该部件的某一均质材料中的含量超出SJ/T 11363-2006的限量要求。

©Copyright 1998 ATEN® International Co., Ltd.  
Manual Part No. PAPE-1134-100  
Printed in Taiwan 01/1999



All brand names and trademarks are the registered property of their respective owners

# Table of Contents

Online Registration .....	1
Overview .....	2
Features .....	2
Switch Configuration .....	3
Operating Modes .....	4
Point-to-Point .....	4
Multidrop.....	5
Simplex .....	8
Installation .....	9
Appendix.....	10
Terminal Block Pin Assignments .....	10
DCE/DTE Connection Description .....	10
SW2 Pin Assignment Schematics .....	10
Troubleshooting .....	11
Specifications .....	12
Radio & TV Interference .....	13

## **Online Registration**

You can register your product at our online support center:

- ♦ International - <http://support.aten.com>
- ♦ North America - [http://www.aten-usa.com/product\\_registration](http://www.aten-usa.com/product_registration)

## **Online Support**

- ♦ Online technical support is available to ATEN customers through our support center:
  - ♦ International - <http://support.aten.com>
  - ♦ North America - <http://www.aten-usa.com/support>.
- ♦ Troubleshooting, Documentation (including online manuals), and Software Updates (firmware and drivers) are available at the ATEN website:
  - ♦ International - <http://www.aten.com>
  - ♦ North America - <http://www.aten-usa.com>

# Overview

The IC-485SN is a bidirectional converter for RS-232 and RS-485/RS-422 interfaces that provides Point to Point, Multidrop, and Simplex operations. A figure showing the names and locations of its features is given below:

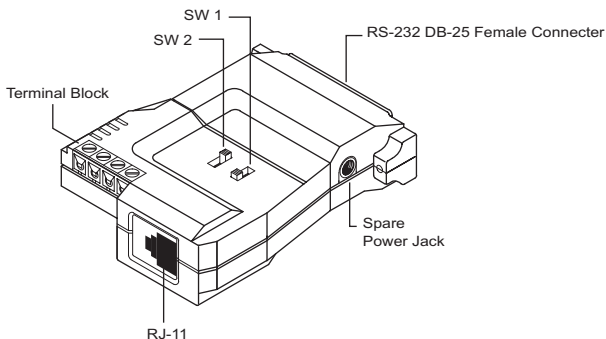

The operating mode, contention control and RS-232C assignments are all configured with two slide switches: SW1 and SW2 (details are given in the *Switch Configuration* section, below).

# Features

- ♦ Data Transmission Controlled by the RTS Signal
- ♦ DCE/DTE Selectable
- ♦ Point to Point/Multidrop, and Simplex/Duplex Operating Modes
- ♦ External Power Not Required - Power Supplied by The RS-232 Interface
- ♦ Compact Size

# Switch Configuration

The IC-485SN is configured by setting two slide switches. SW1 is used to select the IC-485SN's Device Mode; SW2 is used to select the IC-485SN's Transmitting and Receiving Mode, as shown in the table below:

Position	SW1	SW2
1	DCE	TxON, RxON
2	DTE	TxRTS, RxON
3		TxDTR/RTS, RxDSR/ON

An explanation of the SW1 and SW2 terms is given in the table below:

Term	Meaning
DCE	DCE means Data Communication Equipment; if the IC-485SN is going to be plugged into a DTE device, the IC-485SN must be set to DCE.
DTE	DTE means Data Terminal Equipment; if the IC-485SN is going to be plugged into a DCE device, the IC-485SN must be set to DTE.
TxON, RxON	This setting is used in Point-to-Point operations, in which the unit is always in Transmitting and Receiving mode. (See P.10 Schematic)
TxRTS, RxON	This setting is used in Multidrop operations, in which the unit is always in receiving mode and it is in transmitting mode only when the RTS signal is high. (See P.11 Schematic)
TxDTR/RTS, RxDSR/ON	This setting is used in Multidrop Half Duplex operations to monitor the RS-485 line signals. Receiving mode is always ON. DSR is used to check if the line is busy. If not busy, the RTS signal is set high, allowing data transmission. Prior to transmission a DTR signal is sent to keep the other devices from transmitting. (See P.11 Schematic)

# Operating Modes

The IC-485SN supports three operating modes: Point-to-Point, Multidrop, and Simplex. Point-to-Point and Multidrop can be configured for Full Duplex or Half Duplex operation. Each of the operating modes is explained below.

## Point-to-Point

A Point-to-Point configuration is one in which two devices, located at two different places, are linked for communication by a pair of IC-485SN units. There are two configurations: Point-to-Point Full Duplex and Point-to-Point Half Duplex.

### 1. Point-to-Point 4 Wire Full Duplex

- ◆ Point-to-Point Full Duplex uses reverse four wire cabling, as shown in the figure below.

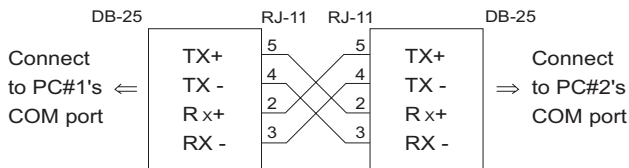

- ◆ For both IC-485SN units, set SW1 to DCE or DTE depending on what type of device the IC-485SN will plug into (if it will plug into a DCE device, configure it for DTE, and vice versa).
- ◆ For both IC-485SN units, set SW2 to TxON, RxON

## 2. Point-to-Point 4 Wire Half Duplex

- ◆Point-to-Point Half Duplex uses straight through four wire cabling, as shown in the figure below:

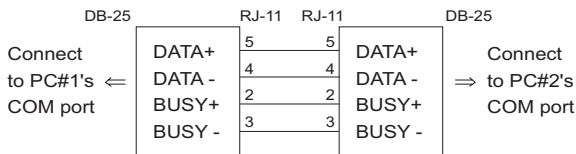

- ◆For both IC-485SN units, set SW1 to DCE or DTE depending on what type of device the IC-485SN will plug into (if it will plug into a DCE device, configure it for DTE, and vice versa).

- ◆For both IC-485SN units, set SW2 to TxDTR/RTS, RxDSR/ON

**Note:** TxDTR/RTS, RxDSR/ON transmitting/receiving mode, involves a straight through Data+, Data-, Busy+, Busy- wiring scheme. See the pin assignment schematic in the Appendix for more Details.

## Multidrop

A Multidrop configuration is one in which more than two devices are linked for communication using several IC-485SN units. Either a two-to-one RJ-11 adapter or a combination of the terminal block and the RJ-11 jack can be used to connect the IC-485SN units to each other. One of the devices that one of the IC-485SN units connects to is assigned to be the master device. The remaining devices that the other IC-485SN units connect to are slave devices. There are two configurations: Multidrop Full Duplex and Multidrop Half Duplex.



## 1. Multidrop 4 Wire Full Duplex

- ♦Multidrop Full Duplex uses reverse four wire cabling to link all the connected IC-485SN units, as shown in the figure below:

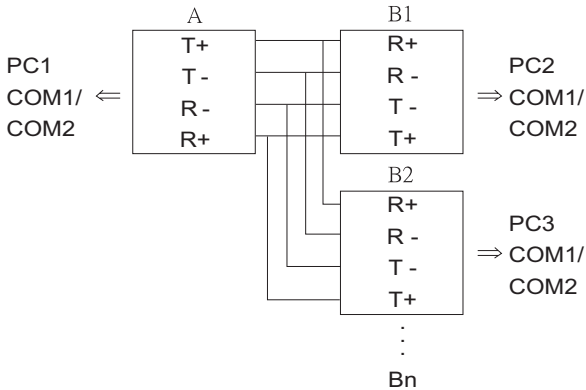

- ♦For all IC-485SN units, set SW1 to DCE or DTE depending on what type of device the IC-485SN will plug into (if it will plug into a DCE device, configure it for DTE, and vice versa).
- ♦For the Master IC-485SN unit, set SW2 to TxON, RxON
- ♦For all Slave IC-485SN units, set SW2 to TxRTS, RxON

## 2. Multidrop Half Duplex

- ♦Multidrop Half Duplex uses straight through four wire cabling to link all the connected IC-485SN units, as shown in the figure below:

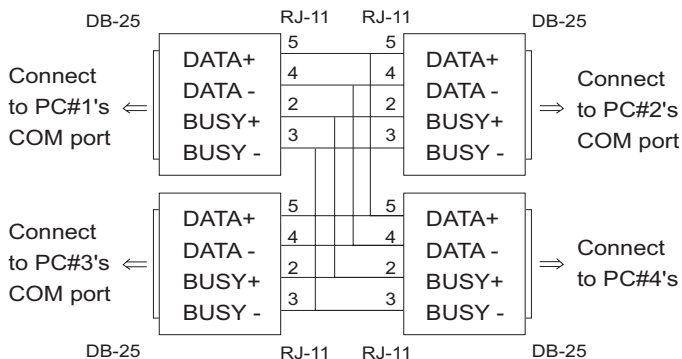

- ♦For all IC-485SN units, set SW1 to DCE or DTE depending on what type of device the IC-485SN will plug into (if it will plug into a DCE device, configure it for DTE, and vice versa).
- ♦For all IC-485SN units, set SW2 to TxDTR/RTS, RxDSR/ON

**Note :** Only one device at a time can talk on the bus (RTS On); during that time, the other devices must remain silent (RTS Off). See the explanation regarding TxDTR/RTS, RxDSR/ON in the table on p. 3.

TxDTR/RTS, RxDSR/ON transmitting/receiving mode, involves a straight through Data+, Data-, Busy+, Busy- wiring scheme. See the pin assignment schematic in the Appendix for more details.

## Simplex

A Simplex configuration is one in which more than two devices are linked for communication using several IC-485SN units in a manner similar to a Multidrop configuration. The difference is that in a Simplex configuration, the master device can only talk, and the slave devices can only listen.

- ♦ Simplex uses reverse two wire cabling to link all the connected IC-485SN units, as shown in the figure below:

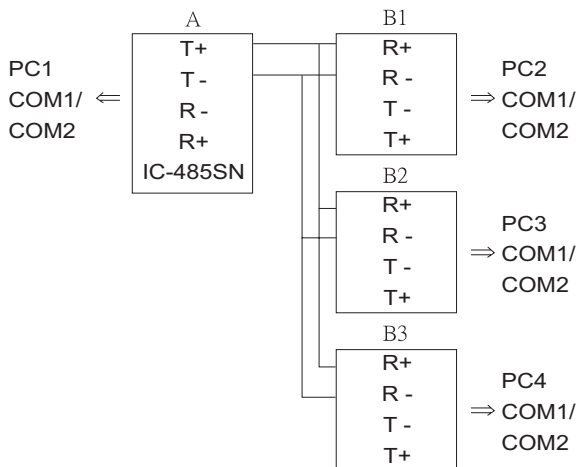

- ♦ For all IC-485SN units, set SW1 to DCE or DTE depending on what type of device the IC-485SN will plug into (if it will plug into a DCE device, configure it for DTE, and vice versa).
- ♦ For all IC-485SN units, set SW2 to TxON, RxON

# Installation

1. Set the configuration switches (SW1 and SW2) according to the information provided in the Switch Configuration and Operation sections.
2. Plug the IC-485SN's DB-25 female connector into the PC's RS-232C port.
3. Use telephone cable to connect one IC-485SN unit to the other.
  - a) Use four wire or two wire cable according to the information given in the Operation section.
  - b) Use reverse or straight through wiring according to the information given in the Operation section.
  - c) You can use the RJ-11 telephone jack, or wire directly to the Terminal Block (see the Appendix for the Terminal Block pin assignments). If you are daisy chaining units, you will need to use either a two-to-one RJ-11 adapter or a combination of the terminal block and the RJ-11 jack.
4. Power On the PC. The unit is now ready for operation.

# Appendix

## Terminal Block Pin Assignments

Pin	Assignment
1	Transmit +V
2	Transmit -V
3	Receive -V
4	Receive +V

## DCE/DTE Connection Description

Device's Connector Pin #				Cable	IC-485S		
DCE DB-9	DTE DB-9	DCE DB-25	DTE DB-25	25/25 9/25 pin		DCE DB-25	DTE DB-25
2	3	3	2	Tx →	Rx →	2	3
3	2	2	3	Rx ←	Tx ←	3	2
8	7	5	4	RTS →	CTS →	4	5
7	8	4	5	CTS ←	RTS ←	5	4
4	6	20	6	DSR ←	DTR ←	6	20
6	4	6	20	DTR →	DSR →	20	6
5	5	7	7		GND ←	7	7

## SW2 Pin Assignment Schematics

**TxON, RxON:**

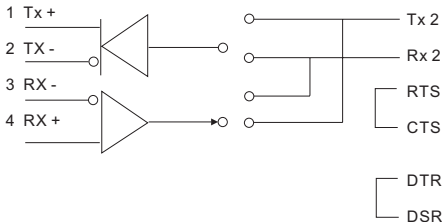

**TxRTS, RxON:**

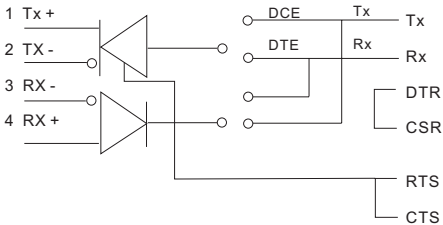

**TxDTR/RTS, RxDSR/ON:**

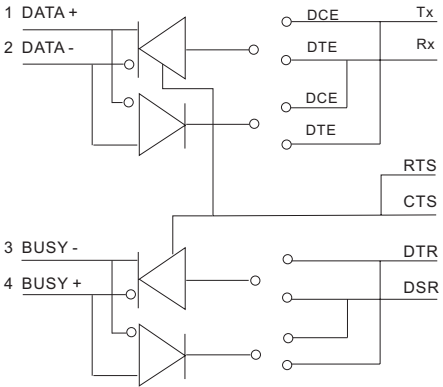

## Specifications

Power Consumption		6.51 mA
Data Rate		Up to 100K bps under 4,000 ft. (1.2 Km)
Connectors	RS-232C	DB-25 female
	RS-485/422	A 4 terminal block or RJ-11
Function Switches	SW1	DCE / DTE Select
	SW2	TxON, RxON TxRTS, RxON TxDTR/RTS, RxDSR/ON
Enclosure		Plastic
Weight		60 g
Dimensions (L x W x H)		54 x 74.5 x 18.5 mm

## Troubleshooting

Problem	Solution
Data Transmission Failure	Check that the IC-485SN units are securely plugged into the PC's serial ports.
	Check that the cables are properly set up and properly connected.
	Check that SW1 and SW2 are set properly.
Data Loss or Error	Check that the Data Rate and Data Format are the same for both devices.

If the above solutions fail to alleviate the problem, contact your dealer for help.

# Radio & TV Interference

Warning. This equipment generates, uses and radiates radio frequency energy and if not installed and used in accordance with the instruction manual may cause interference to radio and television reception. It has been tested and found to comply with the limits for a Class A computing device in accordance with the specifications in Subpart J of Part 15 of the FCC Rules, which are designed to provide reasonable protection against such interference when operated in a commercial environment. Operation of this equipment in a residential area is likely to cause interference, in which case the user at his own expense will be required to take whatever measures may be required to correct the interference.

If this equipment does cause interference to radio or television reception, which can be determined by turning the equipment off and on, the user is encouraged to try to correct the interference by one or more of the following measures:

1. Reorient the receiving antenna.
2. Relocate the computer with respect to the receiver.
3. Move the computer away from the receiver.
4. Plug the computer into a different outlet so that the computer and receiver are on different branch circuits.
5. Ensure that the mounting screws, attachment connector screws and ground wires are tightly secured.
6. Ensure that good quality shielded and grounded cables are used for data communications.

If necessary, the user should consult the dealer or an experienced radio/television technician for additional suggestions.